

REVISION TABLE						
REV	ENG	CHK	APR	APR DATE	DCN	NOTES
B	ZC	MT	MT	06/05/2026	HCG25-0230	FIRST ISSUE

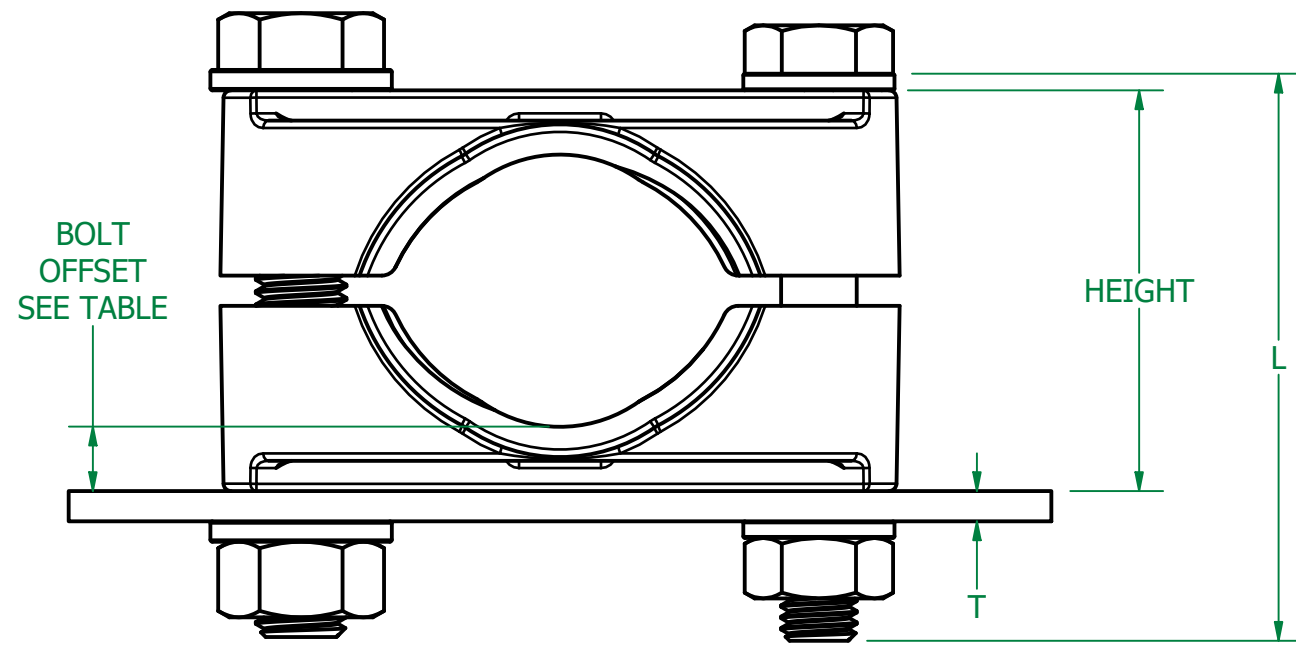

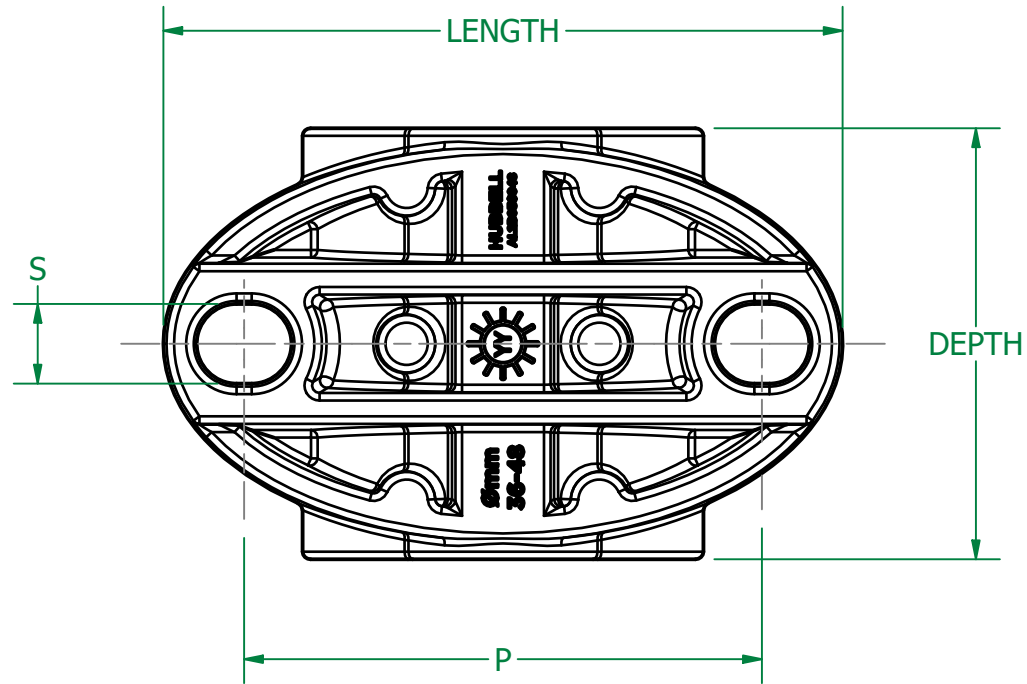

MIN BOLT LENGTH (L) = O*2 + T + D + W*2 + N WHERE
 O = BOLT OFFSET FROM TABLE
 T = SUBSTRATE THICKNESS
 D = CABLE DIAMETER
 W = WASHER
 N = NUT

	DRAWING NUMBER	AL2B Sales GA.idw
	DESCRIPTION	AL2B Sales GA
CONFIDENTIAL & CONTROLLED		
THIS DRAWING SHALL BE USED ONLY AS SPECIFIED BY HUBBELL. ANY OTHER USE, REPRODUCTION, OR DISCLOSURE TO OTHERS WITHOUT WRITTEN PERMISSION IS PROHIBITED. IF PRINTED, THIS DOCUMENT BECOMES AN UNCONTROLLED COPY. THIS DRAWING MAY CONTAIN CERTIFIED PRODUCTS. SPECIFICATIONS SUBJECT TO CHANGE WITHOUT NOTICE.		
3rd ANGLE PROJECTION	UNITS: ^{mm} [INCH]	SALES A3 SHEET 1 OF 2

REVISION TABLE						
REV	ENG	CHK	APR	APR DATE	DCN	NOTES
B	ZC	MT	MT	06/05/2026	HCG25-0230	FIRST ISSUE

CATALOGUE NUMBER	CABLE RANGE mm (inch)	LENGTH mm (inch)	DEPTH mm (inch)	HEIGHT mm (inch)	P (mm)	S FASTENER	MASS PER PAIR g (lb)	BOLT OFFSET mm
AL2B036048	36-48 (1.42-1.89)	90 (3.54)	57 (2.24)	53-67 (2.09-2.64)	66.5-70.5	M10 & 3/8"	84 (0.19)	9
AL2B046058	46-58 (1.81-2.28)	100 (3.94)	67 (2.64)	63-77 (2.48-3.03)	76.5-80.5	M10 & 3/8"	110 (0.24)	9
AL2B056070	56-70 (2.20-2.76)	112 (4.41)	79 (3.11)	73-89 (2.87-3.50)	88.5-92.5	M10 & 3/8"	150 (0.33)	9
AL2B068085	68-85 (2.68-3.35)	133 (5.24)	85 (3.35)	94-113 (3.70-4.45)	106-110	M12 & 1/2"	244 (0.54)	13
AL2B083100	83-100 (3.27-3.94)	148 (5.83)	90 (3.54)	113-132 (4.45-5.20)	121-125	M12 & 1/2"	312 (0.69)	15
AL2B098116	98-116 (3.86-4.57)	164 (6.46)	96 (3.78)	130-150 (5.12-5.91)	137-141	M12 & 1/2"	384 (0.85)	16
AL2B113130	113-130 (4.45-5.12)	179 (7.05)	100 (3.94)	147-166 (5.79-6.54)	151-155	M12 & 1/2"	454 (1.00)	17

	DRAWING NUMBER	AL2B Sales GA.idw
	DESCRIPTION	AL2B Sales GA
<p align="center">CONFIDENTIAL & CONTROLLED</p> <p align="center">THIS DRAWING SHALL BE USED ONLY AS SPECIFIED BY HUBBELL. ANY OTHER USE, REPRODUCTION, OR DISCLOSURE TO OTHERS WITHOUT WRITTEN PERMISSION IS PROHIBITED. IF PRINTED, THIS DOCUMENT BECOMES AN UNCONTROLLED COPY. THIS DRAWING MAY CONTAIN CERTIFIED PRODUCTS. SPECIFICATIONS SUBJECT TO CHANGE WITHOUT NOTICE.</p>		
3rd ANGLE PROJECTION 	UNITS: ^{mm} [INCH]	SALES A3 SHEET 2 OF 2