

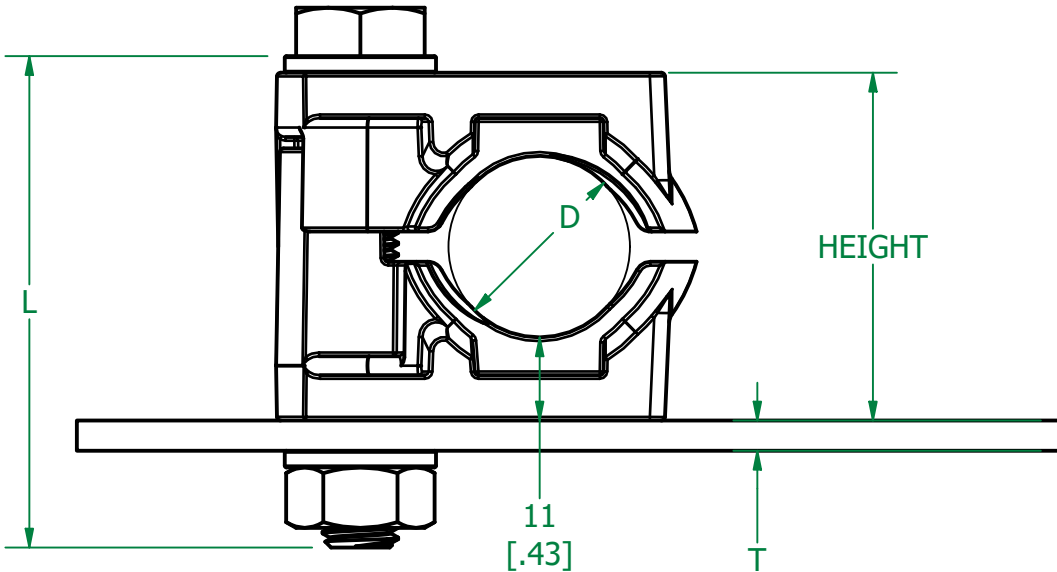

REVISION TABLE						
REV	ENG	CHK	APR	APR DATE	DCN	NOTES
B	ZC	MT	MT	06/05/2026	HCG25-0230	FIRST ISSUE

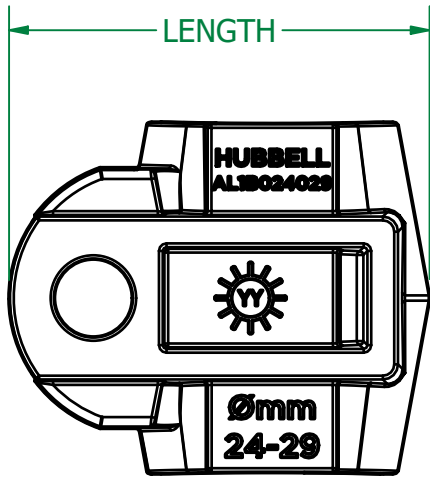



MIN BOLT LENGTH (L) = 22mm + T + D + 2\*W + N  
 WHERE  
 T = SUBSTRATE THICKNESS  
 D = CABLE DIAMETER  
 W = WASHER  
 N = NUT

	DRAWING NUMBER	AL1B Sales GA.idw
	DESCRIPTION	AL1B Sales GA
<p><b>CONFIDENTIAL &amp; CONTROLLED</b></p> <p>THIS DRAWING SHALL BE USED ONLY AS SPECIFIED BY HUBBELL. ANY OTHER USE, REPRODUCTION, OR DISCLOSURE TO OTHERS WITHOUT WRITTEN PERMISSION IS PROHIBITED. IF PRINTED, THIS DOCUMENT BECOMES AN UNCONTROLLED COPY. THIS DRAWING MAY CONTAIN CERTIFIED PRODUCTS. SPECIFICATIONS SUBJECT TO CHANGE WITHOUT NOTICE.</p>		
3rd ANGLE PROJECTION 	UNITS: mm [INCH]	SALES   A4   SHEET 1 OF 2

REVISION TABLE						
REV	ENG	CHK	APR	APR DATE	DCN	NOTES
B	ZC	MT	MT	06/05/2026	HCG25-0230	FIRST ISSUE

CATALOGUE NUMBER	SIZE RANGE mm (inch)	LENGTH mm (inch)	HEIGHT mm (inch)	MASS PER PAIR g (lb)
AL1B018022	18-22 (0.71-0.87)	48.5 (1.91)	40-46 (1.57-1.81)	34 (0.07)
AL1B021025	21-25 (0.83-0.98)	51.6 (2.03)	43-49 (1.69-1.93)	36 (0.08)
AL1B024029	24-29 (0.94-1.14)	55.6 (2.19)	46-53 (1.81-2.09)	42 (0.09)
AL1B028033	28-33 (1.10-1.30)	59.7 (2.35)	50-57 (1.97-2.24)	46 (0.10)
AL1B032041	32-41 (1.26-1.61)	67.1 (2.64)	54-65 (2.13-2.56)	52 (0.11)
AL1B040049	40-49 (1.57-1.93)	75.3 (2.96)	62-73 (2.44-2.87)	62 (0.14)
AL1B048057	48-57 (1.89-2.24)	83.4 (3.28)	70-81 (2.76-3.19)	74 (0.16)

	DRAWING NUMBER	AL1B Sales GA.idw		
	DESCRIPTION	AL1B Sales GA		
<b>CONFIDENTIAL &amp; CONTROLLED</b> THIS DRAWING SHALL BE USED ONLY AS SPECIFIED BY HUBBELL. ANY OTHER USE, REPRODUCTION, OR DISCLOSURE TO OTHERS WITHOUT WRITTEN PERMISSION IS PROHIBITED. IF PRINTED, THIS DOCUMENT BECOMES AN UNCONTROLLED COPY. THIS DRAWING MAY CONTAIN CERTIFIED PRODUCTS. SPECIFICATIONS SUBJECT TO CHANGE WITHOUT NOTICE.				
3rd ANGLE PROJECTION 	UNITS: $\frac{\text{mm}}{[\text{INCH}]}$	SALES	A4	SHEET 2 OF 2